

1
a

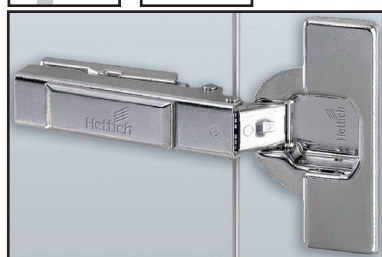

INTERMAT 9936



- Charnière automatique à clipser
- Pour portes à moulures jusqu'à 32 mm
- Pour épaisseur de porte de 14 à 32 mm
- Diamètre de boîtier 35 mm
- Profondeur du pot: 11,1 mm (fixe: 11,6 mm)
- Réglage de recouvrement intégré +2 mm/-2 mm
- Réglage en profondeur intégré 4 mm
- Réglage en hauteur par embase
- Boîtier/bras de charnière: acier nickelé

MODELES DE BOÎTIERS

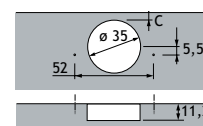





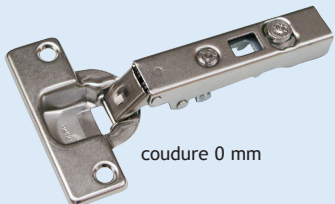
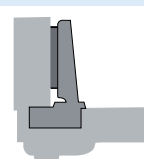

COTES DE PERCAGE

9936 - TH 42

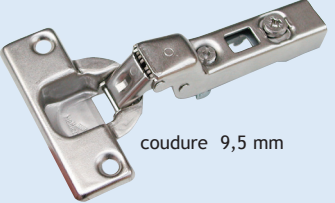
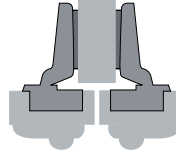
- à visser

Amortisseurs pour charnières voir p. 1.19

MODELES DE CHARNIERES	TYPE DE FERRAGE	CODE
 coudure 0 mm	 en applique	1011-3700 
 coudure 9,5 mm	 en demi-applique	1011-3710 
 coudure 16 mm	 rentrant	1011-3716 

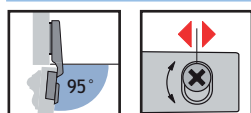

modèles de boîtiers ø 40 mm!!!
 mèche HSS - ø 40 mm
 0303-5040

INTERMAT 9935

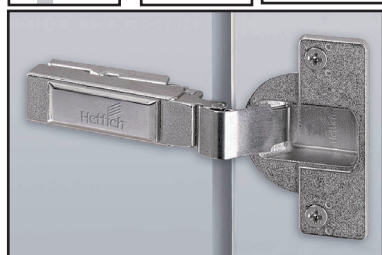

- Charnière automatique à clipser
- Pour portes à moulures jusqu'à 43 mm
- Pour épaisseur de porte de 16 à 43 mm
- **Diamètre de boîtier 40 mm**
- Profondeur du pot: 13,7 mm
- Réglage de recouvrement intégré +0,5 mm/-3 mm
- Réglage en profondeur intégré 4 mm
- Réglage en hauteur par embase
- Boîtier/bras de charnière: acier nickelé

MODELES DE BOÎTIERS

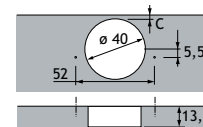









COTES DE PERCAGE

9935 - TH 22

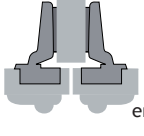
- à visser

Amortisseurs pour charnières voir p. 1.19

MODELES DE CHARNIERES	TYPE DE FERRAGE	CODE
 coudure -5 mm	 en applique	1011-4700 
 coudure 5 mm	 en demi-applique	1011-4710 
 coudure 16 mm	 rentrant	1011-4716 